

GRD800 Series 80G FM Radar Level Sensor





Principle

GRD800 series 80G radar level gauge adopts frequency modulated continuous wave (FMCW) technology. The antenna emits a high-frequency FM radar signal, and the frequency of the radar signal increases linearly. The transmitted radar signal is received by the same antenna after being reflected by the measured medium. At the same time, the frequency difference between the transmitted signal frequency and the received signal frequency is proportional to the measured distance. The collected frequency difference signal is subjected to fast Fourier transform (FFT) to obtain the spectrum of the reflected echo, and the distance to the target to be measured is calculated based on this.

Feature

- Millimeter wave radar, the measurement accuracy can reach up to $\pm 2\text{mm}$, and the minimum measurement blind zone is 0.05m.
- The smaller antenna size satisfies the measurement of more working conditions.
- A variety of lens antennas, smaller launch angles, more concentrated energy, stronger echo signals, and higher reliability than other radar products under the same industrial and mining conditions.
- It has stronger penetration and can be used normally in the case of adhesion and condensation.
- The dynamic signal range is larger, and the measurement of low dielectric constant media is more stable.
- Multiple measurement modes, radar response in fast measurement mode

<p>GRD805</p>  <p>The image shows the GRD805 sensor, which has a blue upper housing with two ports on the left side. It is connected to a silver metal flange with a threaded neck and a white lens antenna at the bottom.</p>	<p>Medium: strong corrosive liquid, steam, foam, high temperature. and high pressure Measuring range: 0.1m~10/20/30/60/100m Process connection: flange \geq DN80 Process temperature: -40~200°C Process pressure: -0.1~2.5MPa Antenna size: 76mm lens antenna (according to flange size) Antenna material: PTFE/overall filling Accuracy: \pm1mm Protection class: IP67 Center frequency: 80GHz Launch angle: 3° Power supply: two-wire /DC24V four-wire /DC12~24V four-wire /AC220V Casing: aluminum / plastic / stainless steel Signal output: two-wire /4...20mA/HART protocol four-wire 4...20mA/ RS485 Modbus</p>
<p>GRD806</p>  <p>The image shows the GRD806 sensor, which has a blue upper housing with two ports on the left side. It is connected to a silver metal flange with a threaded neck and a white lens antenna at the bottom.</p>	<p>Medium: solid, storage container, process container, strong dust application Measuring range: 0.3m~10/20/30/60/100m Process connection: flange \geq DN100 Process temperature: -40~110°C Process pressure: -0.1~0.3MPa Antenna size: 76mm lens antenna (purge optional) Antenna material: PTFE Accuracy: \pm1mm Protection class: IP67 Center frequency: 80GHz Launch angle: 3° Power supply: two-wire /DC24V four-wire /DC12~24V four-wire /AC220V Casing: aluminum/plastic/stainless steel Signal output: two-wire /4...20mA/HART protocol</p>

four-wire 4...20mA/ RS485 Modbus

Installation

Installation Method

1: thread installation (GRD801)

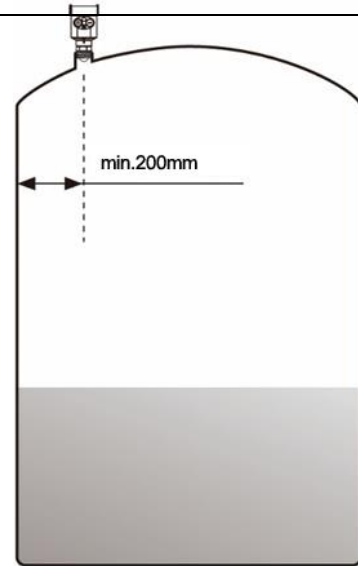

2: Flange Installation

When using flange installation, the minimum distance between the instrument and the tank wall should be 200mm.

- ① datum plane
- ② vessel center or axis of symmetry

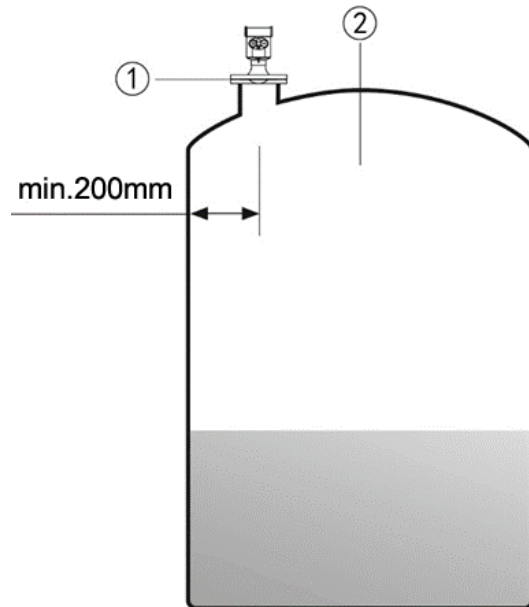
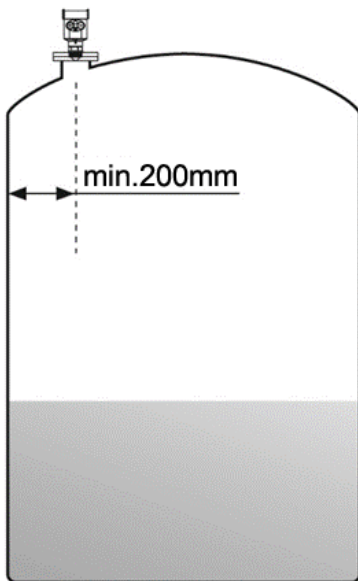

3: Hoisting Installation

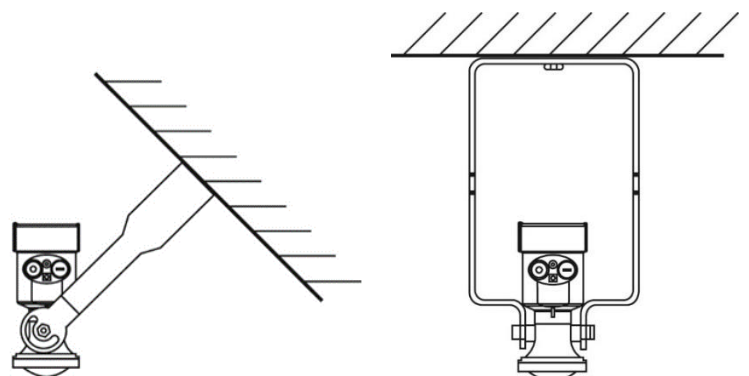
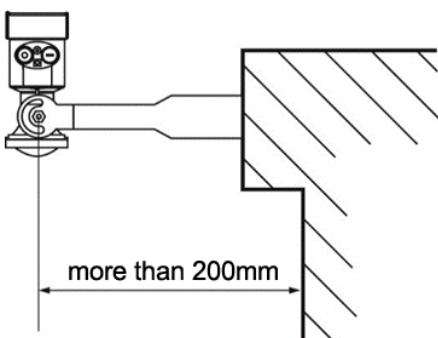

Installation Requirements

When installing the instrument, avoid installing it above the material inlet, and try to avoid various objects that affect the signal, such as stirring paddles, etc.

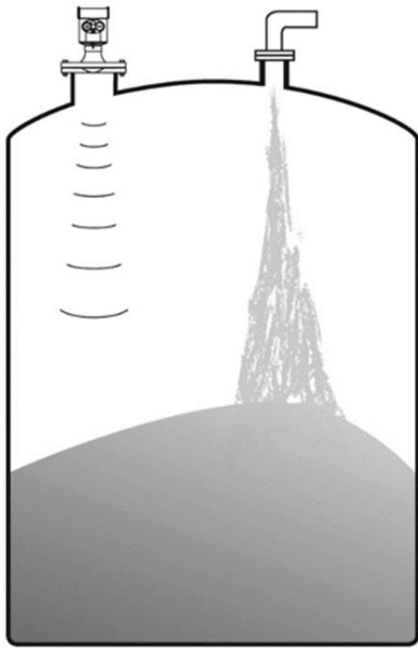

solid

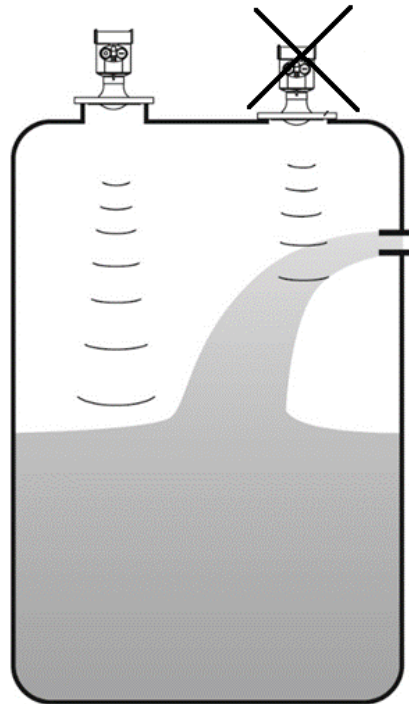

liquid

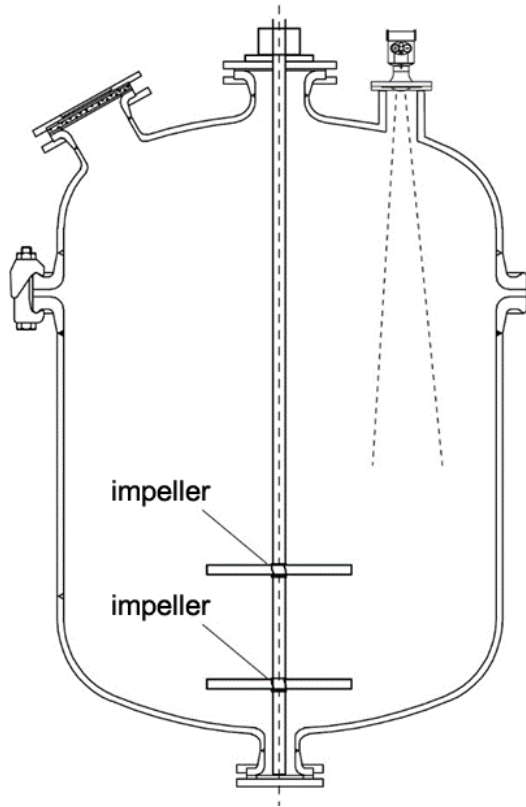

Under extremely complex working conditions, the instrument can work normally if there is no obstacle in the area with a radius of 20cm centered on the installation point.

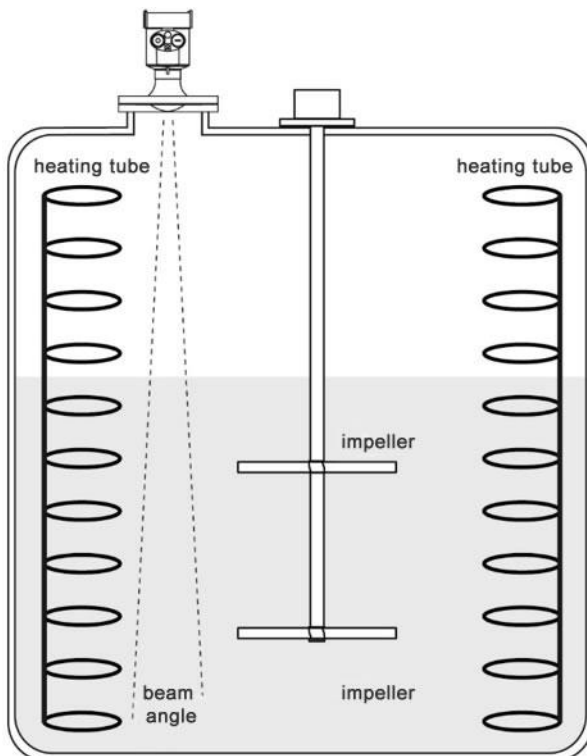

Installation Connection Diagram

The maximum installation spool height H_{max} depends on the installation spool diameter D and the size of the product launch angle.

Too long installation connection will affect the radar performance.

GRD801/02

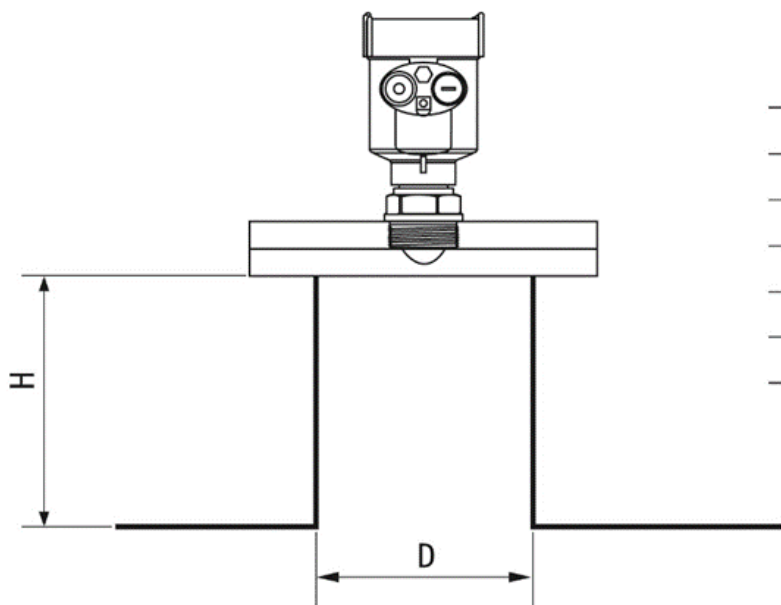

Flange	D	H max
DN65	65mm (2.5")	600mm
DN80	80mm (3")	800mm
DN100	100mm (4")	1000mm
DN125	125mm (5")	1200mm
DN150	150mm (6")	1400mm

GRD803/GRD804G/GRD805

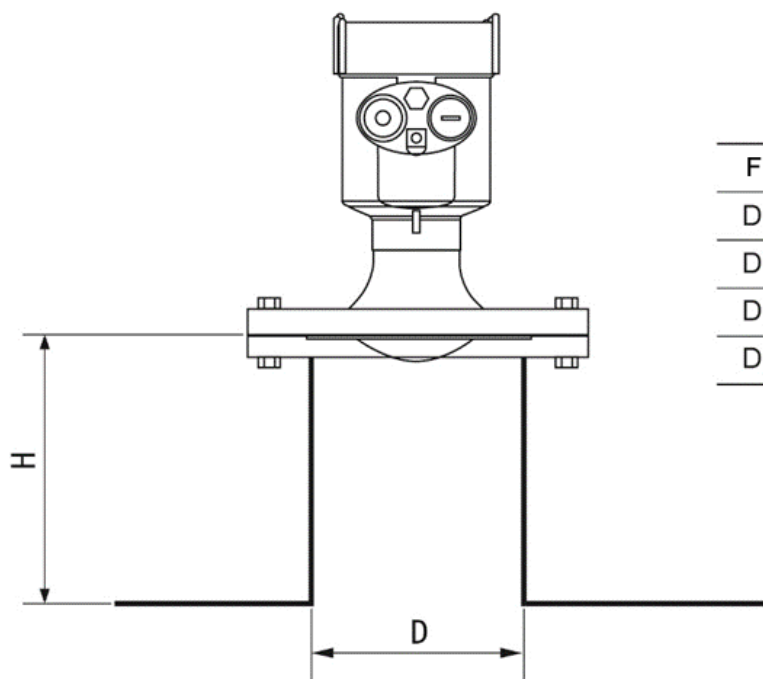

Flange	D	H max
DN80	80mm (3")	1200mm
DN100	100mm (4")	1500mm
DN125	125mm (5")	2000mm
DN150	150mm (6")	2500mm

GRD806

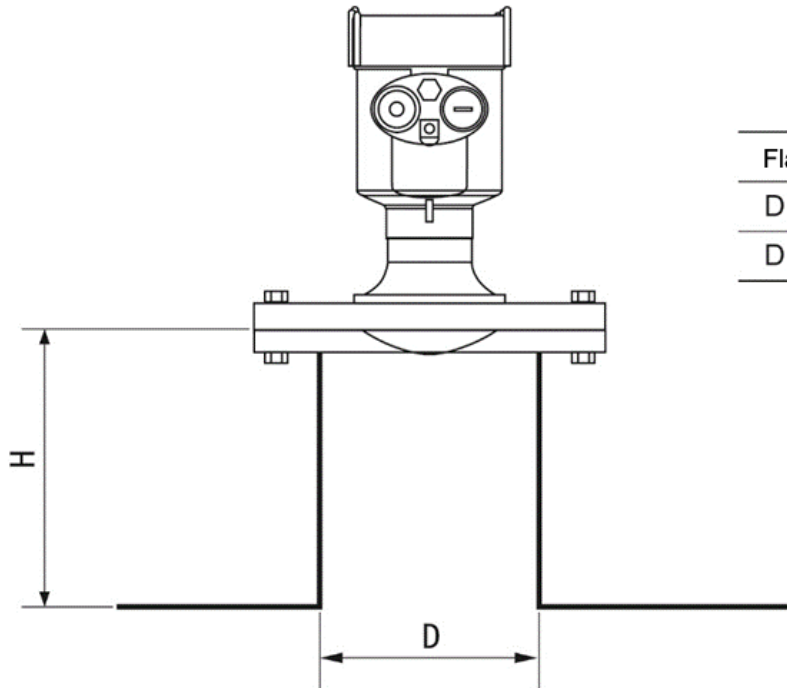

Flange	D	H max
DN125	125mm (5")	4000mm
DN150	150mm (6")	5000mm

Electrical Connection

Power Supply

(4~20) mA/HART(2 wire)

The power supply and the output current signal share a two-core shielded cable. Please refer to the technical data for the specific supply voltage range.

(4~20) mA (4 wire/6 wire)

The power supply needs to be powered separately, and a four-core shielded cable is used for the power supply and current signal (the current signal and the RS485 interface can be output at the same time, and a six-core shielded cable is required for simultaneous output).

RS485/Modbus

The power supply needs to be powered separately, and a four-core shielded cable is used for power supply and digital signal.

(The current signal and the RS485 interface can be output at the same time, and a six-core shielded cable is required for simultaneous output).

Connection

24V two wire:

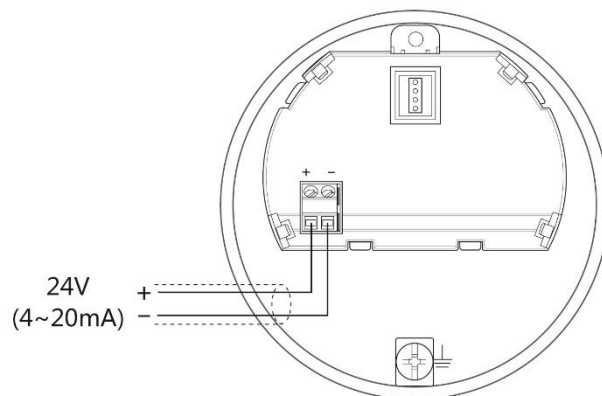

12~24V four wire:

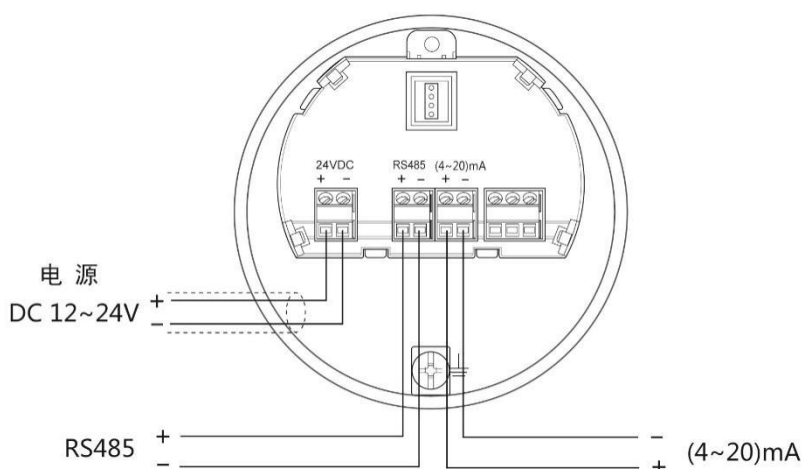

Safety Guide

Please observe the requirements of the local electrical installation regulations!
Follow local regulations for personnel health and safety. All operations on the electrical components of the instrument must be completed by professionals who have received formal training.

Please check the nameplate of the instrument to ensure that the product specification meets your requirements. Please ensure that the power supply voltage is consistent with the requirements on the nameplate of the instrument.

Grade of Protection

This instrument fully meets the requirements of protection class IP66/67, please ensure the waterproofness of the cable sealing head. As shown below:

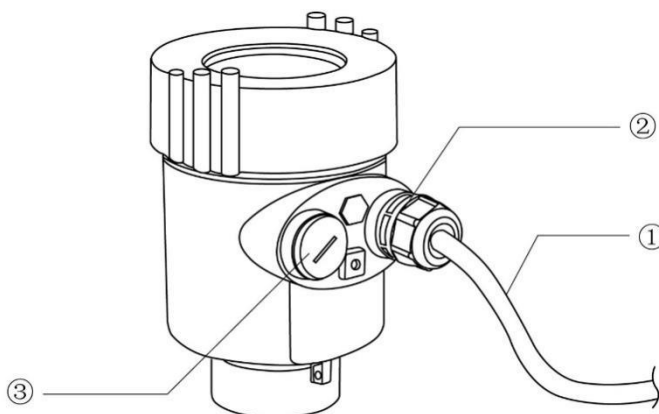

How to ensure that the installation meets the requirements of IP67:

Make sure the sealing head is not damaged.

Make sure the cable is not damaged.

Please make sure that the cables used meet the requirements of the electrical connection regulations.

Before entering the electrical interface, bend the cable down to ensure that water will not flow into the housing, see ①

Please tighten the cable gland, see ②

Please plug the unused electrical interface with a blind plug, see ③

Dimensions

Casing Dimension

Unit in mm:

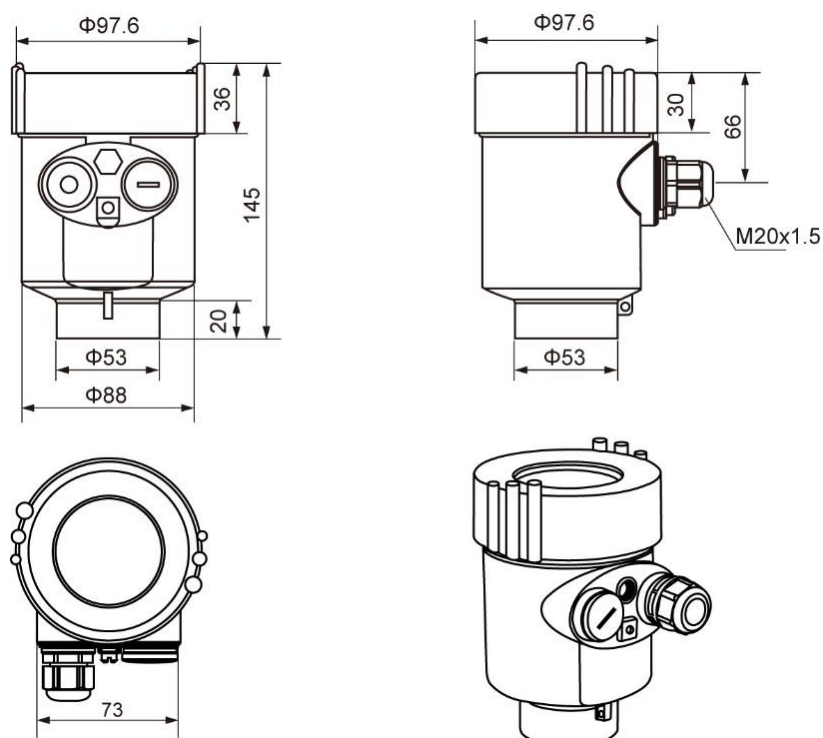

Product Dimension

Unit in mm:

GRD801

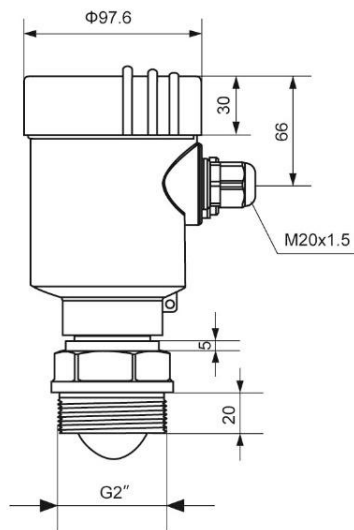
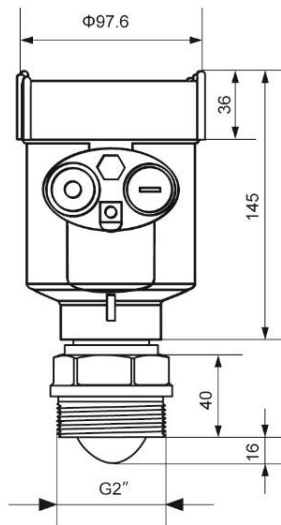
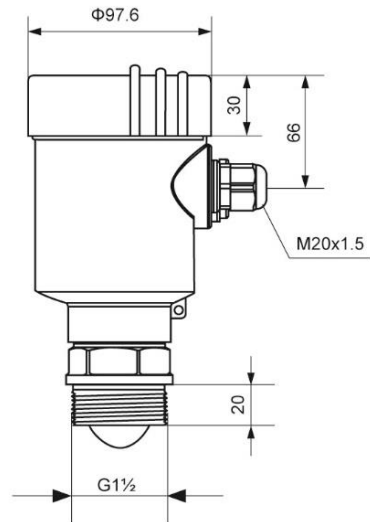
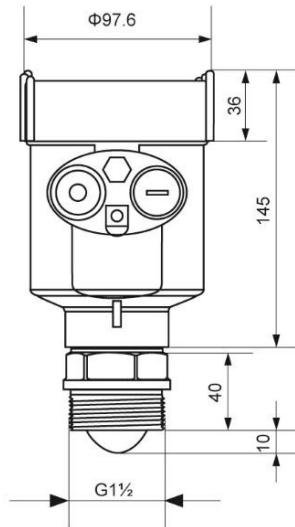

GRD802

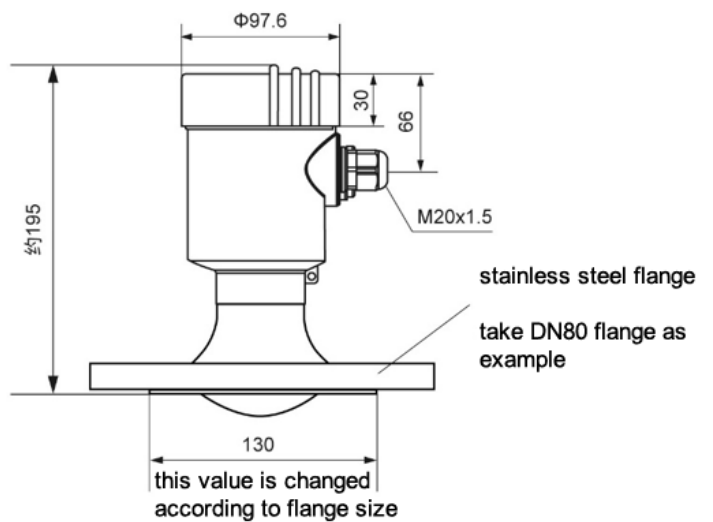
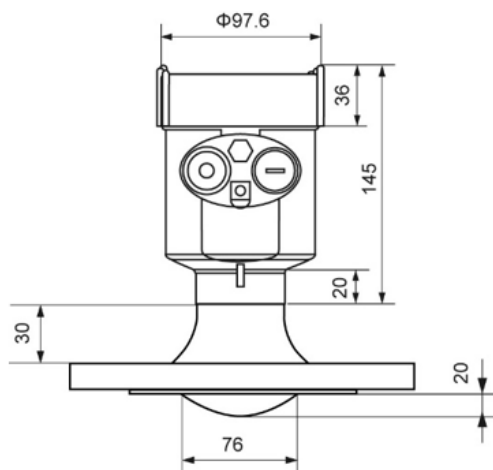

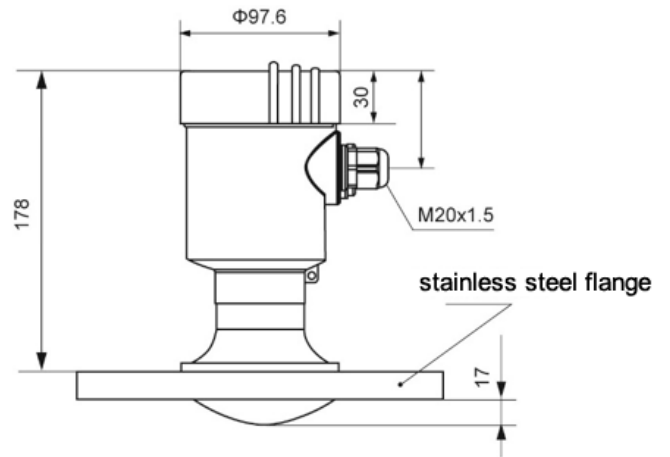
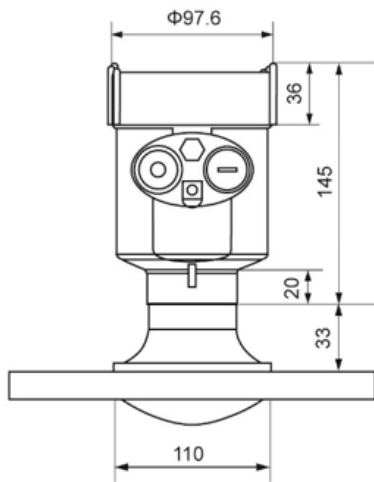

GRD803

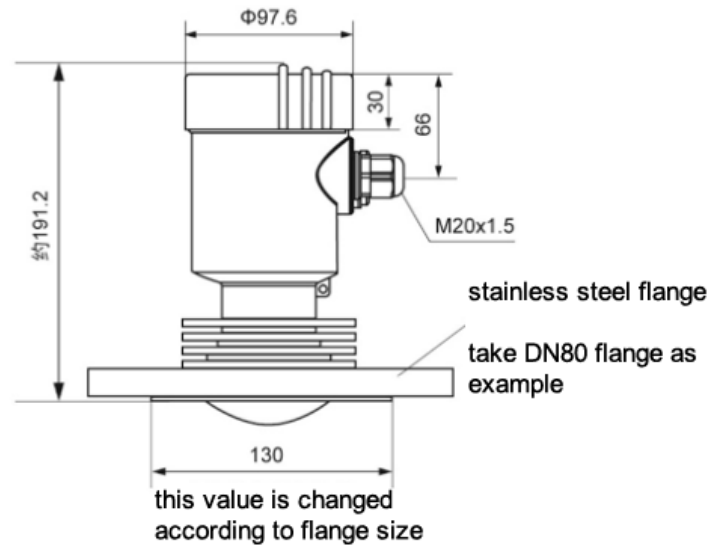
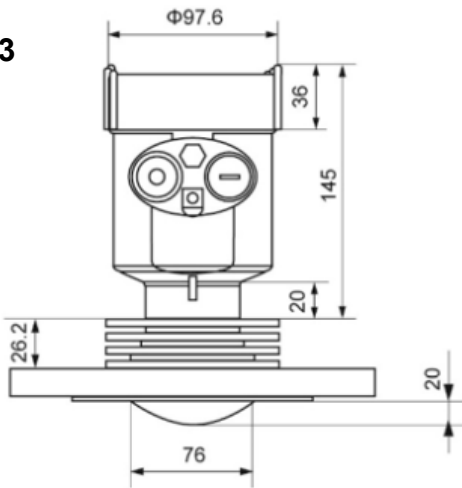

GRD804

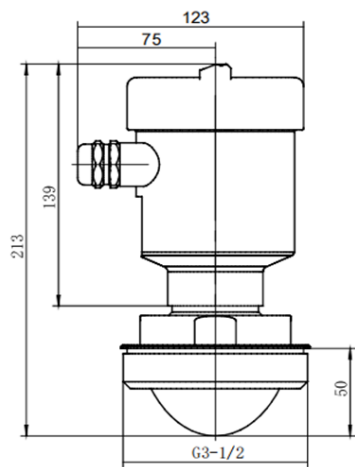

GRD805

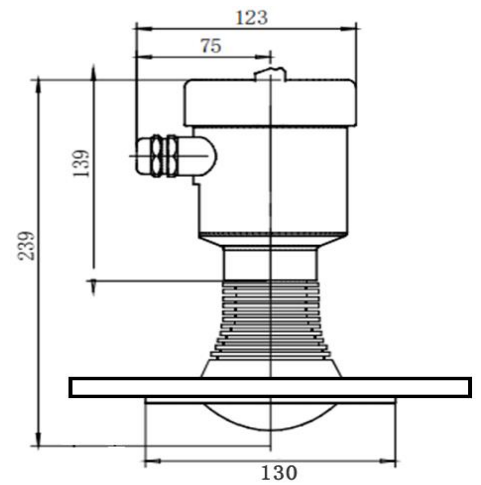

GRD806

with air purge

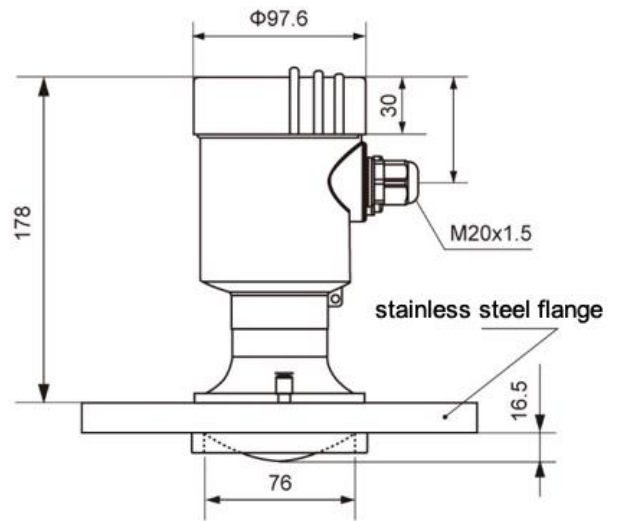
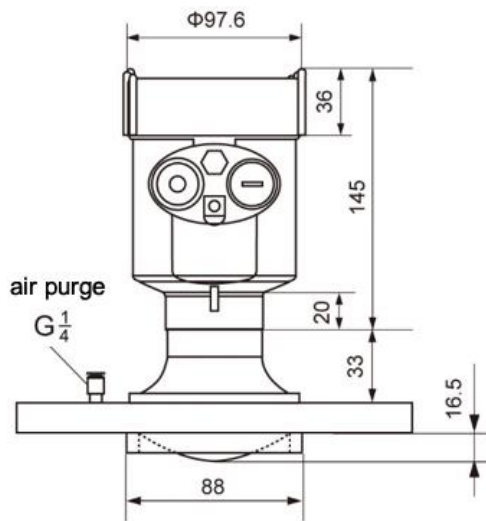

without air purge

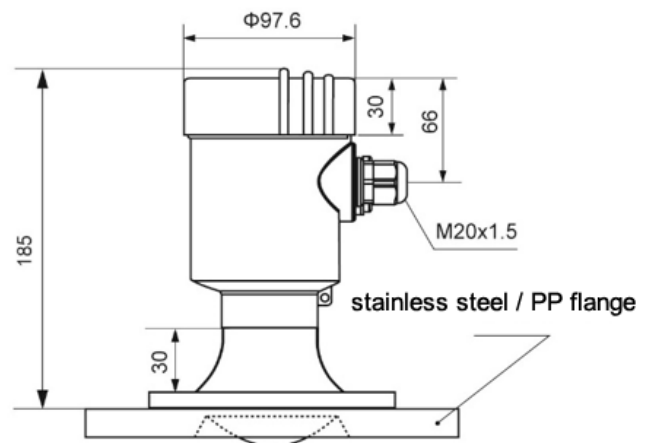
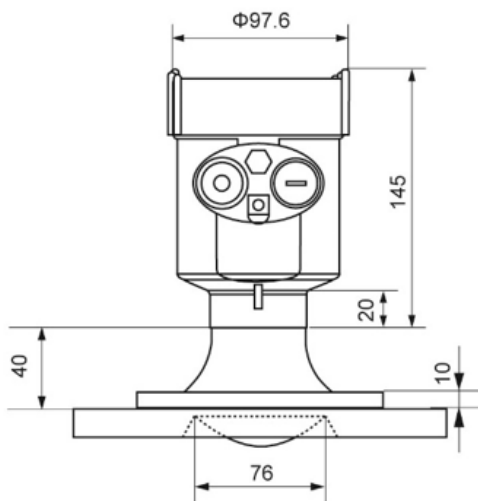

Technical Specifications

General Data

Process Connection

Antenna Material

Casing

Seal Between Case and Cover

Casing Window

Ground Terminal

flange / material 304 stainless steel, PP

PTFE

cast aluminum/stainless steel

FKM

transparent PC

stainless steel

Power Supply

2-wire, single chamber (4-20mA)	standard	(12-24)VDC
	intrinsically safe	(12-24)VDC
	power consumption	max.22.5mA
	allowable ripple	
	- <100Hz	$U_{ss} < 1V$
2-wire, two chamber (4-20mA)	-(100~100K) Hz	$U_{ss} < 10mV$
	intrinsically safe + isolation	(18-25) VDC
4-wire, single chamber (RS485)	power consumption	max .15W
	intrinsically safe	24(1±10%)V DC
	power consumption	max .12mA
4-wire, two chamber (4-20mA)	intrinsically safe + isolation	220VAC
	power consumption	max .18mA

Cable Parameter

Cable Entry/Plug	one M20x1.5 cable entry, cable dia. 5...9MM one blind plug M20x1.5
Terminal Block	wire cross-section 2.5mm ²

Output Parameter

Output Signal	(4~20) mA / HART RS485/Modbus
Resolution	1mm
Fault Signal	output unchanged; 20. 5mA; 22mA; 3.9mA
Integration Time	(0~40)s, adjustable
Blind Zone	0.1m/0.2m/0.3m
Max. Measurement Distance	150 meters
Measurement Interval	approx. 1s (depending on settings)
Adjustment Time	approx. 1s (depending on settings)
Work storage and Transportation Temp.	(-40~80) °C
Relative Humidity	< 95%
Pressure	Max. 2.5MPa
Shock Resistance	Mechanical vibration 10m/s ² , (10~150)Hz

